

1992

HM 544

englisch

OPERATING INSTRUCTIONS

Mobil 544 engl. 192

Dear Eriba-Hymer Customer,

Before you begin leafing your way through the pages of the user manual for your new motorcaravan, may we extend to you a warm welcome as new members of the large Eriba-Hymer family.

The following user manual seeks to familiarise you with the operation and care of your motorcaravan. Important safety points and a lot of tips and motivations will help ensure that you get many years of enjoyment from your vehicle. Please read and take care of the following instructions.

Turn to your authorised Eriba-Hymer dealer for the regular servicing of your vehicle or whenever you need help of any kind. Remember that, when it comes to customer services, your authorised Eriba-Hymer dealer is the one who best knows and understands your vehicle and is most interested in satisfying your wishes.

Along with the vehicle, you should have received from us:

- a service record booklet for the base vehicle
- a guarantee booklet for the 6 year vehicle seal warranty, and
- various instruction booklets for the base vehicle as well as the different built-in appliances.

We would also like to take this opportunity to thank you for having decided for an Eriba-Hymer product. We are sure that you will get a lot of pleasure from your motorcaravan and we wish you, always and everywhere you go, a pleasant journey.

If you still have unanswered questions, your Eriba-Hymer dealer will be happy to help you.

Yours ERIBA-HYMER GmbH

1	Safety And Accident Prevention Instructions		8	Electrical Appliances	
	- General	03		- Supply	27
	- Traffic Safety	03		- 12 Volt Fuse Box.....	29
	- Gas System	03		- Circuit Diagram	30
				- Fridge	31
				- Air Circulation	32
2	Before Your Journey		9	Toilet Facilities	
	- Bringing Into Service			- Water Supply	33
	For The First Time	05		- Washbasins	33
	- Loading	05		- Washroom	33
	- Entrance Steps	06	10	Maintenance	
	- Testing For Road Worthiness	07		- Maintenance Of The Exterior	35
	- Checking Tyre Pressures	07		- Internal Maintenance	35
	- Testing The Gas System	08		- Winter Maintenance.....	35
				- Laying Up The Vehicle.....	36
				- Major Valeting	38
3	During Your Journey		11	Aftercare And Servicing	
	- Driving The Motorcaravan	09		- Servicing	39
	- Braking	09		- Official Inspections.....	39
	- Seating Regulations	10		- Spare Parts	40
4	At The End Of Your Journey		12	In An Emergency	
	- Handbrake	11		- Changing A Wheel.....	41
	- Chocks	11		- Faults Guide	41
	- Entrance Steps	11	13	Index Of Service Stations	
5	Parking Your Motorcaravan			- Dealers list- West Germany	45
	- Vehicle Supports	13		- Eriba-Hymer Euro-Service	49
	- Caravan Door.....	13	14	Technical Data	
	- Exterior Connection.....	15		- Position Of Number Plates	51
6	Living Area			- Pressures Guide For Tyres	51
	- Ventilation.....	17		- Table Of Technical Data	53
	- Sliding window	17			
	- Extending Window	18			
	- Roof Ventilation.....	19			
	- Preparing The Sleeping				
	Quarters.....	19			
7	Gas Appliances				
	- General	23			
	- Heating	23			
	- Cooker.....	24			
	- Fridge	25			
	- Boiler	26			

General

- o Always ensure a sufficient ventilation if you are staying in your motorcaravan. Never cover up the built-in ventilation grille with a winter mat or similar as this could lead to the danger of asphyxiation from the build up of carbon dioxide.
- o The makers' instructions for the built-in appliances (gas heating system, cooker, fridge etc.) as well as for the base vehicle (engine, brakes etc.) are extremely important. Follow them at all times!
- o When using the entrance or driver's door, always be aware of the height of the opening.
- o When leaving your motorcaravan, you have to close all doors and windows securely!

Traffic Safety

- o When driving, passengers should only be on the seats provided.
- o When loading the motorcaravan, always observe the prescribed gross and axle weights.
- o The vehicle load must be distributed evenly across the motorcaravan (see section 2 "Loading").
- o Make sure before driving away that the suspended double bed or the cab roof bed is fastened securely to the roof by both safety belts (Hymermobil respectively Hymertramp).
- o Check before driving away that you have removed the support from beneath the vehicle.
- o Before driving away, close the motorcaravan doors and make sure that the steps are fully retracted (note the lights on the dashboard).
- o Pay attention, that the extending windows are closed while driving.
- o Only allow an authorised garage to check and repair your braking systems.
- o You should also be aware of the fact that adding accessories can affect the measurements, the weight and the driving characteristics of your vehicle.
- o When stationary, the handbrakes on the motorcaravan must be engaged to the maximum setting possible; on an incline, you should use chocks under the wheels. Above 4.6 tonnes gross weight, chocks must be used.
- o In winter, the roof must be cleared of snow and ice before driving away.

Gas System

- o You should not make any repairs or alterations to the gas system yourself. Always find a specialist to undertake the work.
- o When there is a defect in the gas system (if you can smell gas or the appliance is using too much), switch the appliance off immediately and ventilate the area. Get a specialist to look into the fault as soon as possible. If there is a smell of gas, don't use any electrical switches (starter, light switches etc.), and don't allow smoking or open flames.

1 Safety And Accident Prevention Instructions

- Before you use devices with an open flame (gas cooker, gas lights, gas heater, boiler etc.) the roof light and ventilator must be opened (see also section 1 "General").
- A gas cooker or oven should never be used as a form of heating.
- When not using gas cooker or other gas appliance, the valve on the gas bottle should be closed.
- If several gas appliances are in use, each outlet should have its own gas tap which should be closed whenever the appliance is not in use.
- Because of the danger of explosions, no naked lights (gas cooker, gas heater, boiler etc.) should be in use when filling up the fuel tank.
- Either 11 kg or 5 kg gas bottles can be used. Camping gas bottles (blue bottles with 2,5 or 3 kg contents) are not allowed. Be careful to ensure that the gas bottles are securely fastened.
- Be aware that Propane gas can be used in temperatures down to -32 °C; Butane gas only down to -2 °C.
- While driving, the valves on the gas bottles must be closed.

Bringing Into Service For The First Time

The number plates will need to be firmly screwed in place (depending on the model) either on the bumper or between the number plate lights.

For this operation:

- use only self-tapping screws.
- bore two holes, slightly greater in diameter than the diameter of the screws used, at suitable points on the number plate.
- hold the number plate up to the motorcaravan and mark on the vehicle the positions of the holes already bored.
- drill the fastening holes with the same diameter as the self-tapping screws which are being used.
- either place a compounding agent in the holes or onto the screws.
- screw the number plate tightly into place.

The best place for the national plate is under the offside rear light.

ATTENTION Please make sure that you tighten the wheel nuts after about 50 km on your first journey. Later on, from time to time, check that they are still fastened tightly (100 Nm \pm 10 Nm).

Loading

When loading a Hyermobil you should ensure that heavy items are stored as low down as possible, i.e. close to floor level. Lighter articles can be accommodated in the roof storage spaces. By following this rule you will ensure a low centre of gravity and consequently favourable road holding and driving characteristics.

Only the difference between the vehicle's kerb weight and its gross weight may be loaded. An overload is not permissible. The weights for your particular vehicle can be read off the log book (paras 14 and 15).

ATTENTION Take into consideration that the weight of the persons who accompany you has to be included in loading.

TIP We recommend in the interests of your own safety that you weigh the loaded vehicle before driving away (included the weight of the persons, who accompany you).

The Fiat rear suspension comprises several layers. If the vehicle is unloaded, the springs are horizontal. When loaded, the springs bend downwards giving the impression that the vehicle is overloaded. This behaviour is progressively corrected; that is, when first the vehicle is loaded the spring reacts "softly" and then becomes increasingly "hard" as loading continues. Don't get worried if, when fully loaded according to the gross weight for the vehicle, the springs are bent downwards.

ATTENTION The maximum permissible roof load stands at 75 kg.

2 Before Your Journey

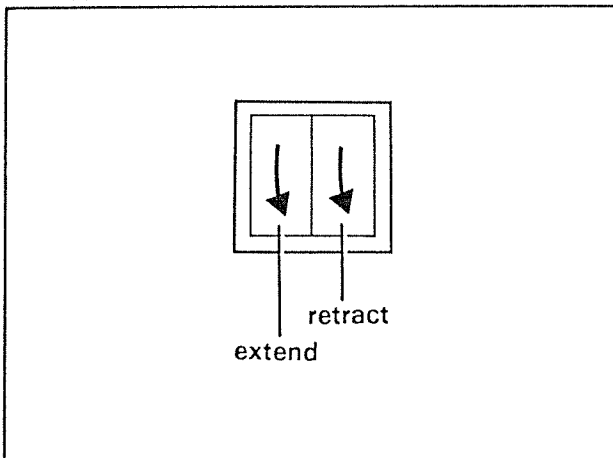
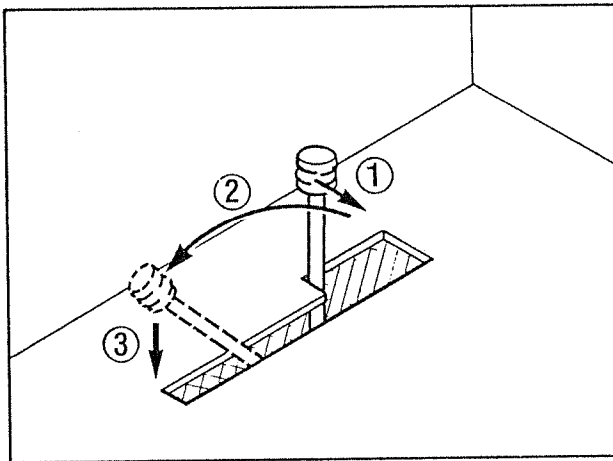
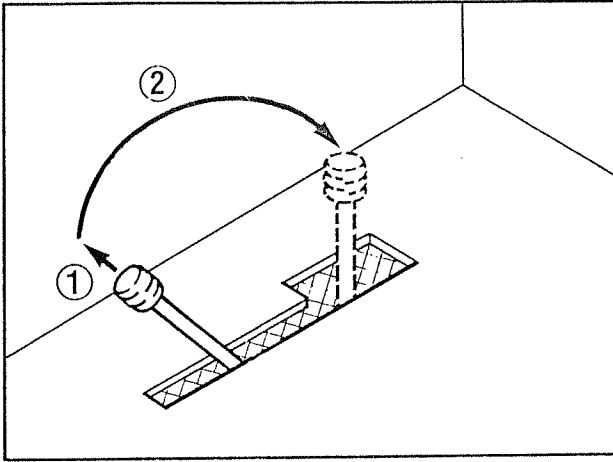

Entrance Steps

- o Mechanically operated entrance steps

To retract the steps

- lift the lever upwards (1),
- hold the lever up and
- push the lever forwards until you hear the steps click into position (2).

To extend the steps

- push the lever to the right to dislodge it from the rest position (1),
- pull the lever to the rear (2) and
- release slowly (3).

- o Electrically operated entrance steps

By operating the appropriate rocker switch in the entrance area, you can extend or retract the steps as required.

ATTENTION Make sure, before every journey, that the steps are fully retracted.

In the Fiat and Peugeot models, the control light for the handbrake is coupled with that for the entrance steps. The control light will only go out when the handbrake is off and the steps are fully retracted.

In the Mercedes models, the fourth control light from the top is for the entrance steps.

Testing For Road Worthiness

- o Make sure that two external mirrors are attached to the motorcaravan.
- o Ensure before driving away that you have removed or retracted the vehicle supports.
- o Close the motorcaravan entrance door firmly and make sure that the steps are fully retracted (see control light).
- o In winter, the roof must be cleared of snow and ice before driving away.
- o Make sure that all the extending windows and roof vents are closed and the cab roof - as far as existing - is closed too.
- o Make sure before driving away that the suspended double bed or the cab roof bed is fastened securely to the roof by both safety belts (Hymermobil respectively Hymertramp).
- o Check whether all drawers and cupboard doors are closed and that the safety catch on the fridge door is engaged.
- o Fix the curtains into place using the cord provided.
- o Make certain that the extra safety bolts on the upper and lower halves of the door (as well as the childproof lock) are in place.
- o Check the motorcaravan vehicle lights before every journey.
- o Store loose items or tie them down so that they don't begin to move around during the journey. (This applies to parts left in the storage boxes as well as to free standing tables etc.).
- o The front bench of the central seating group (Hymermobil 544, 554, 564 and 660) can have its backrest turned around to provide for "bus style" seating.
- o Don't forget to check the oil and coolant levels before setting off.

Checking Tyre Pressures

Please check the tyre pressures on your motorcaravan regularly before setting off (see section 14 "Technical Data").

2 Before Your Journey

Testing The Gas System

Make sure before you start any journey that the valves on the gas bottles are closed tightly and that the bottles themselves are strapped firmly in place.

Driving The Motorcaravan

Remember that, as the driver, you are responsible for seeing that:

- the passengers remain seated in their places (take note of the seating regulations),
- the door bolts remain unopened and
- the safety rules mentioned in sections 1 and 2 are adhered to.

Avoid unnecessary, severe braking and drive slowly on poor road surfaces.

Be aware when driving a larger vehicle that, because of the relatively long overhang between the rear axle and the rear bumper, it can stick out or, in certain conditions, "run aground".

You should watch out for this particularly when driving onto ferries, when crossing uneven ground and when reversing as extra care is required here. By doing this, you will help to prevent damage to the working parts underneath the vehicle.

Putting on your seat belt should, by now, be taken for granted.

TIP The base vehicle is really built as a small goods vehicle. Your driving style should take account of this fact and make the necessary changes.

ATTENTION Make sure at the beginning of every journey and also after short breaks in a journey (such as at the filling station) that the entrance steps are fully retracted before moving off.

Braking

Please check at the beginning of every journey by "test-braking" whether:

- the brakes on your motorcaravan are working,
- the brakes are pulling evenly and
- the motorcaravan tracks properly when braking.

ATTENTION If you find any part of your braking system defective, get an authorised dealer to inspect the system immediately in the interests of your own safety.

3 During Your Journey

Seating Regulations

ATTENTION When in motion, persons are only allowed on the statutory seats.

The official recognized seats can be found in the log book (para 12).

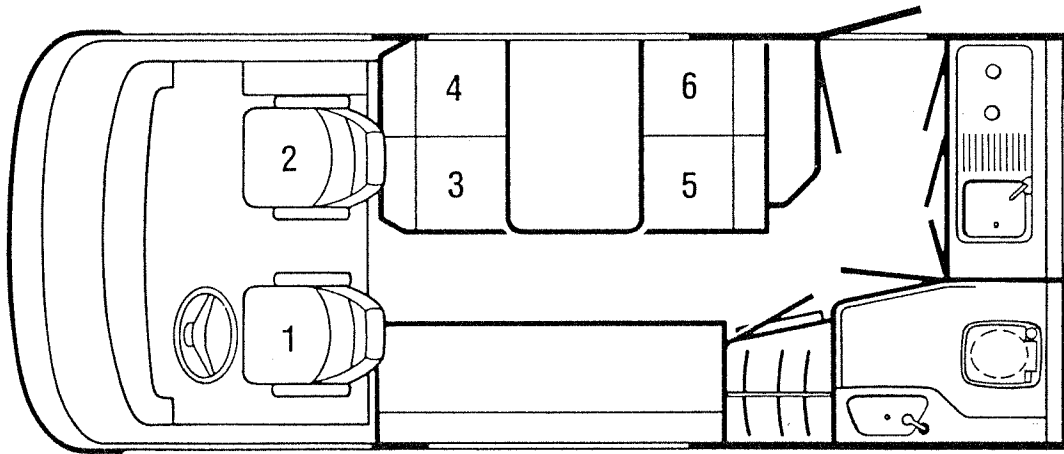

Hymermobil 544

Handbrake

When parking the vehicle the handbrake must be pulled on firmly (particularly on an incline).

Chocks

Use chocks when parked on inclines. Above 4.6 tonnes gross weight chocks are obligatory. These can be found in the same box as the gas bottles.

Below 4,6 tonnes gross weight we recommend the use of chocks under the wheels. Your Eriba-Hymer dealer will gladly advise you.

Entrance Steps

When leaving the vehicle, the entrance steps have to be fully extended. Control light is on the dashboard.

Vehicle Supports

In order to stabilise the motorcaravan you can use vehicle supports. Set them down round the sides of the vehicle. They must not however, under any circumstances, be placed directly under the vehicle floor.

ATTENTION Don't use supports for heaving the vehicle (for example when changing a wheel). The supports only have a limited loading capacity; they only serve for stabilising the installed motorcaravan.

TIP When out in the countryside it is best to use small planks of wood as a platform for the supports.

By extending the vehicle supports, and there isn't enough ground, you have to lift your motorcaravan by using the lifting-jack (set down round the sides of the vehicle).

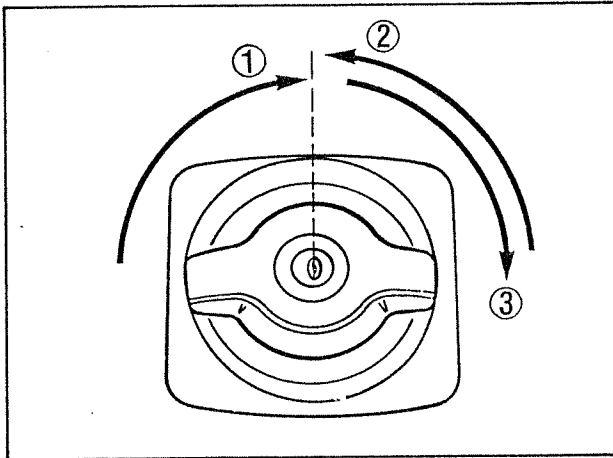

Caravan Door

Opening a locked door:

- Put the key in the lock and turn clockwise until the lock clicks into place (1).
- Turn the key back to its central position (2) and pull out.

For an unlocked door turn the door handle clockwise (3) until the lock engages

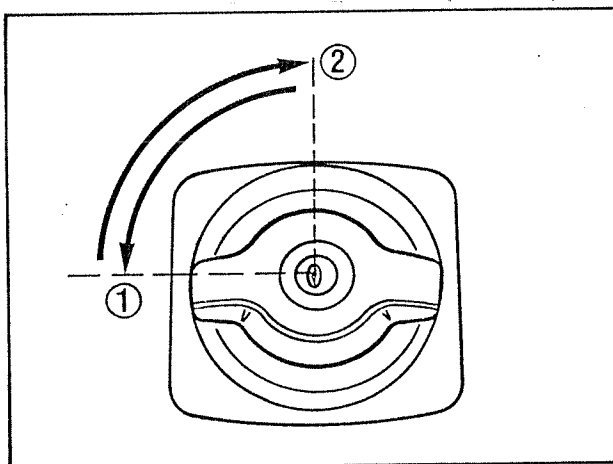

To lock the door:

- Put the key in the lock and turn 90 degrees anticlockwise (1).
- Turn key back to central position (2) and pull it out.

5 Parking Your Motorcaravan

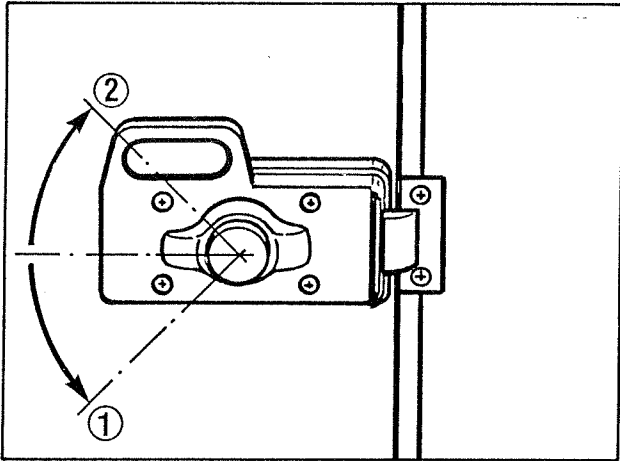

To open the door from inside, turn the door knob anti - clockwise (1).

If you wish to lock the door from the inside, turn the door knob clockwise about 45 degrees and leave it in this position (2).

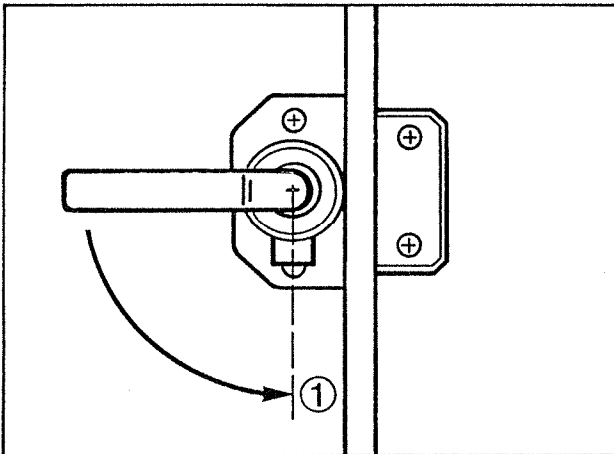

You can also open just the top part of the door. In order to do this:

- bolt down the lower part of the door with the handle turned 90 degrees downwards (1), and

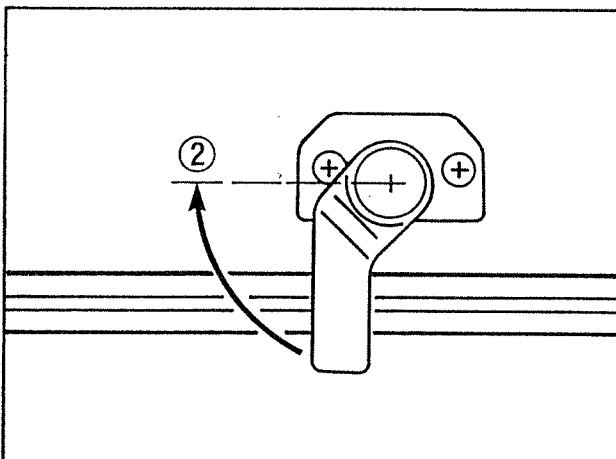

- move the locking handle on the upper part of the door into a horizontal position.

Ventilation

Always take into consideration please, that the oxygen inside your vehicle will be used up, by

- People breathing,
- Cooking facilities as well as
- Gas light etc.

For this reason it is necessary to allow a continuous flow of oxygen through the vehicle. In order to ensure a sufficient air supply we have installed a statutory air vent in your vehicle (e.g. in the sky light).

In addition, take care to ensure a continual change of air through specific ventilation points. Only in this way can you overcome the problem of condensation in cold weather conditions. Together with an efficient heating system, through well calculated bursts of heat, ventilation and airing, you can always achieve a pleasant living climate during the cooler times of the year or when camping in the winter.

When your vehicle is at home don't forget to give it an airing from time to time. Before using after the vehicle has been laid up, ventilate your vehicle in any case; specially in summertime by a possible heat accumulation.

TIP In certain cold weather conditions despite adequate ventilation, condensation can be found on metal surfaces (e.g. the floor to undercarriage fixings).

Also note that seams around roof vents, plugs, filling caps and flaps can cause further cold spots.

ATTENTION Under no circumstances cover over the statutory air vent which we have installed (e.g. with an insulation mat); this leads to the danger of asphyxiation due to increased levels of carbon dioxide.

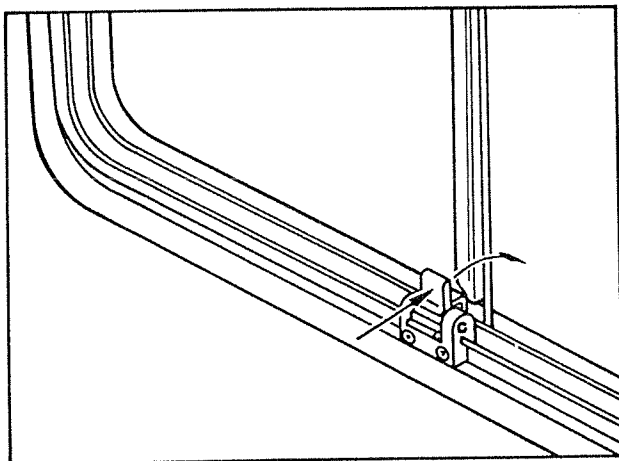

Sliding window (driver's door)

To open:

- Tip the bolt inside.
- Window can be opened.

To close:

- Close the window till stop.
- Press the bolt outside.

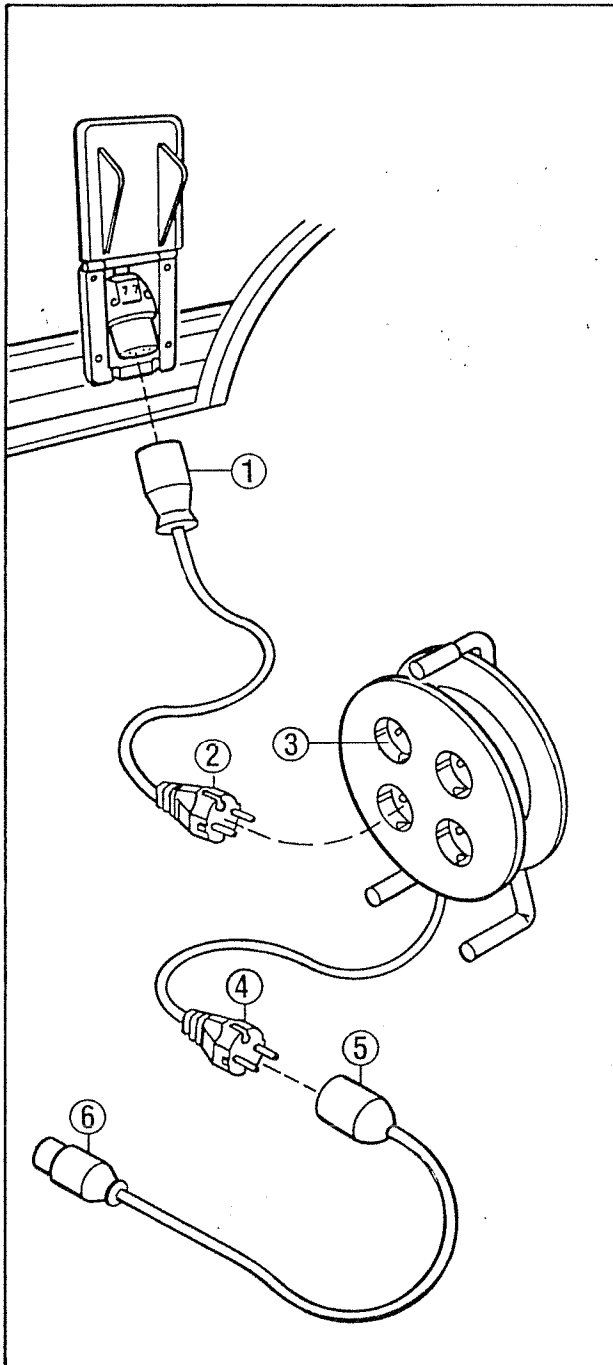

Exterior Connection

The electrical connection between the motorcaravan and the 220 V network is to be made using a three core flex inside a flexible rubber cable with a minimum cross section 3 x 2,5 mm and with a plug which meets the DIN 49462 norm.

In order to be equipped for every eventuality, we recommend the following combinations:

- Adapter cable:
EC socket (1) → Schuko plug (2),
- Cable drum:
Schuko socket (3) → Schuko plug (4),
- Adapter cable:
Schuko-socket (5) → EC plug (6).

Your Eriba-Hymer dealer will always be ready to supply you with the necessary parts.

ATTENTION In the accessory catalogue cable drums with a thermo-fuse against overabundant warming are offered. Only by using these cable drums, the cable hasn't to be unrolled off the cable drum.

6 Living Area

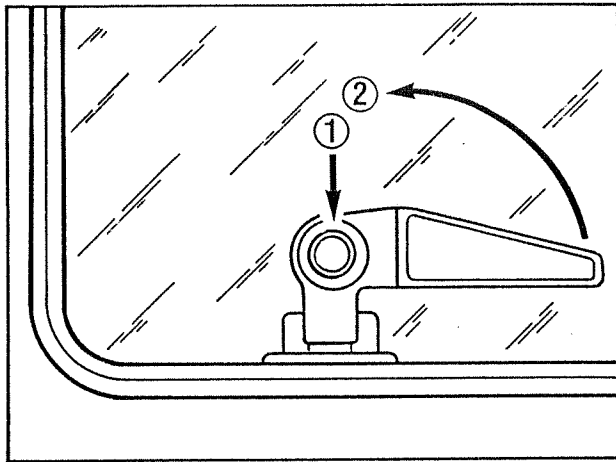

Extending Window

- o Window with automatic positioning

To open:

- Press security button (1).
- Turn locking handle to vertical position (2).
- Loosen the security screw on the telescopic arms (front and rear windows).
- Lift the security screw out of its holder.
- Move the window to the desired position; the telescopic arms will lock automatically in that position.

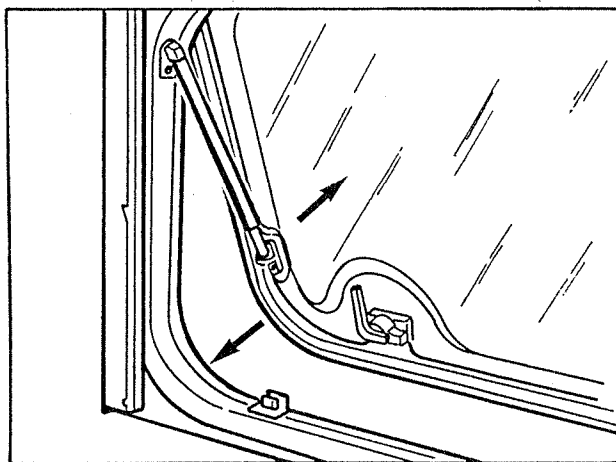

To close:

- Push the window a little further out, until the stop is released.
- Close the window.

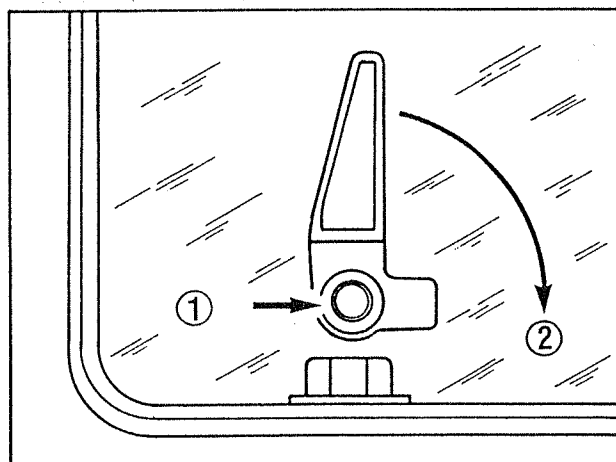

- Push the security button (1).
- Turn the locking handle into the horizontal position (2).
- For the front and rear windows slot the security screw on the telescopic arms into the holder and screw it moderately tight.

The locking handles enable the windows to be put in two different positions:

- Slightly open ventilation position or
- Fully closed position.

ATTENTION For windows with ratchet arms the window must be opened fully in order to release the catch. If the catch is not properly free, there is a danger that the window will buckle with the strain of being forcefully pulled back.

Roof Ventilation

- o Handle operated roof vent

Depending on the direction in which the roof vent lever is turned, you can raise (open) or lower (close) the vent. You can adjust it as you please. The mosquito net should be placed over the rubber gasket above the four corner knobs (not visible from the inside).

- o Roof vent with a winding mechanism

Depending on the direction in which the handle turns, the vent can be freely opened or closed to any fixed position.

- o Snap-effect roof vent

Opening or closing is effected by a light push or pull on both of the handles.

TIP Depending on the weather, make sure the roof vent or windows are closed tightly enough to prevent any damp entering the motorcaravan.

Preparing The Sleeping Quarters

- o Driver's and passenger's seats

The driver's and passenger's seats can be converted by turning the handle in front of the seat. The rear of the seat can be moved by using the lever at the side of the seat. If you want to turn the passenger's seat (if possible), this one is to place totally forwards. The arresting handle for the rotary mechanism you will find in the front under the seat.

- o Double bed in driver's cab area (suspended bed in the Hyermobil)

Place the driver's and front seat passenger's seats as far to the rear as they will go. Loosen both of the straps which provide extra stability for the extra bed in the roof of the vehicle. Pull the bed downwards with both hands. To prevent damage you are advised to close the curtains on the forward side windows before lowering the bed. The stabiliser straps should be used to prevent users from falling out of the bed.

- o Suspended double bed above the seating group area (Hyermotram)

Push the driver's and front seat passenger's seats forwards and then lie the backs of the seats flat. Loosen both of the straps which provide extra stability for the extra bed in the roof of the vehicle. Pull the bed downwards with both hands. If you only require two sleeping places you will have achieved the necessary conversion by this means.

In order to use the double bed as part of the seating group lift the bed with both hands until the first ratchet clicks into place. Both back rests can be set in place again. The bed has three ratchet settings in all. These can be used to set the height of the bed and allow the seating group to be used at the same time as the bed.

6 Living Area

- TIP** Both the collapsible double bed and the suspended bed are designed to provide sleeping space for two people and are not intended for use as extra luggage space. When the bed is not in use, therefore, only the bedding for two people should be stored in it.
- ATTENTION** Make sure before you drive away that the collapsible double bed or the suspended bed are firmly secured to the roof by the straps provided.

Before conversion

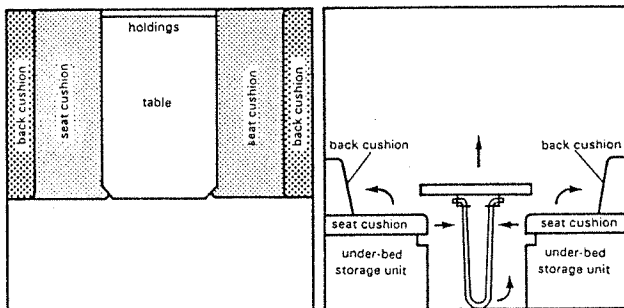

o Middle seating group

Converting to sleeping quarters:

- Lift up the table top carefully to the front.
- Compress the table leg at the top and tip on the underside of the table.
- Lift up the table top about 45 degrees; then lift the table out of the holdings and put it to one side.
- Set up both cushions.
- Put the table between both under-bed storage units.

During conversion

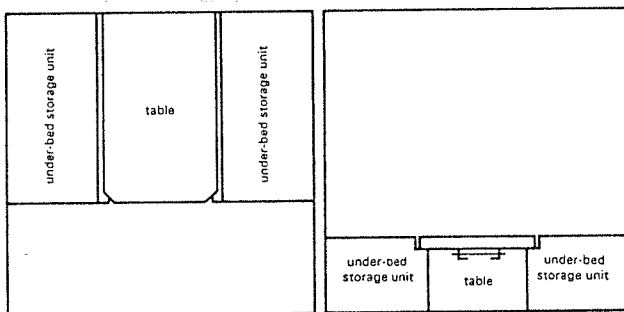

After conversion

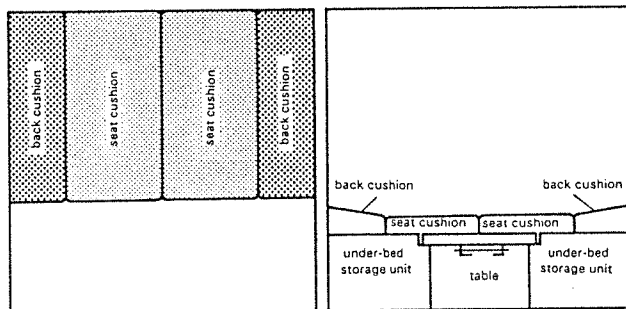

- Put both seat cushions into the middle.
- Push down the back rests between the seat cushions and the wall. Take the wedge shape of the back cushions into consideration when placing them into position.

6 Living Area

Before conversion

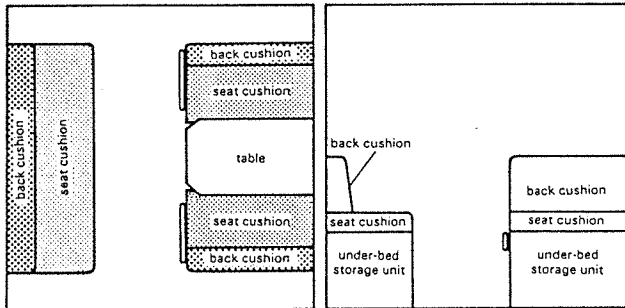

During conversion

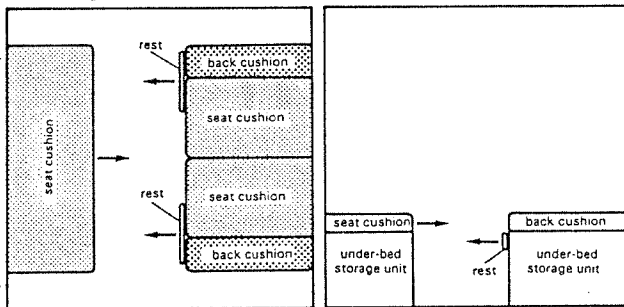

After conversion

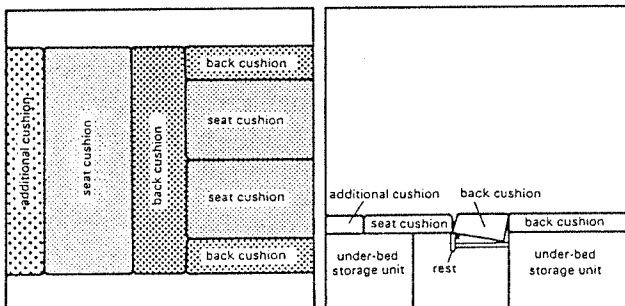

- o Middle seating group with couch

Converting to sleeping quarters:

- Convert the middle seating group for sleeping (see the foregoing page).

- Pull out the rests at both sides of the under-bed storage units of the middle seating group till stop.
- Pull out the seat cushions of the opposite seating couch.

- Lay the back cushions of the seating couch on both rests. The extension rods have to be within the rests. Take the wedge shape of the back cushions into consideration, when placing them into position.
- Fit both additional cushions (to be found in the wardrobe) in between the seat cushions and the outer wall.

General

The installed appliances are regulated for propane or butane or for a mixture of both gases. The regulator, along with all installed appliances, are set for a 50 mbars pressure.

ATTENTION Propane is usable down to $-32\text{ }^{\circ}\text{C}$, Butane only to $-2\text{ }^{\circ}\text{C}$.

When the cooker (or other gas appliances) are not in use, the main cut-off valve on the gas bottle must be closed.

If several gas appliances are in use, each outlet should have its own cut-off tap which should be closed whenever the appliance is not in use.

Before using devices with an open flame (gas cooker, gas lights, gas heater, boiler etc.) the roof light and ventilator must be opened (see also section 1 "General").

A gas cooker or oven should never be used as a form of heating.

The ignition cutouts are self closing mechanisms. Check that they are functioning properly from time to time. After the gas flame on a particular appliance has been extinguished, the ignition cutout should close within a minute. An audible click indicates that this has happened.

Both 11 kg and 5 kg gas bottles may be used. Camping gas bottles (blue bottles containing 2.5 or 3 kg) are not allowed.

TIP The gas bottle is, both because of its function and its construction, open to the outside air and is not, therefore, protected against damp.

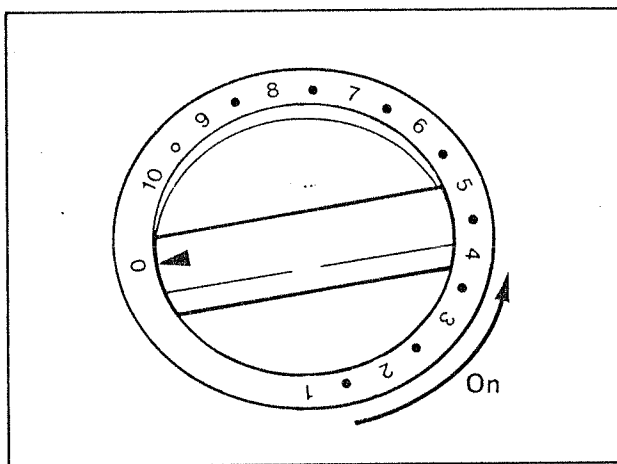

Heating

To switch on the heating:

- Open the main cut-off valve (bottle valve) and the appliance cut-off valve (heating).
- Turn the regulator on the heater to the desired position.
- The automatic ignition will produce sparks. A clicking sound will be heard and the control lamp will blink.
- Push in the regulator until a flame lights. Keep pressing for a further ten seconds until the ignition cutout engages. If the gas goes out, wait for two minutes before attempting to re-ignite.

ATTENTION Above levels 3 to 4 the circulating fan should be switched on to guard against overheating of the heater.

Never let unlighted gas leak out because of the danger of explosions.

Fridge

The fridge has two modes of operation:

- Liquid gas operation,
- Electrical operation (220 Volt AC or 12 Volt DC; see electrical appliances).

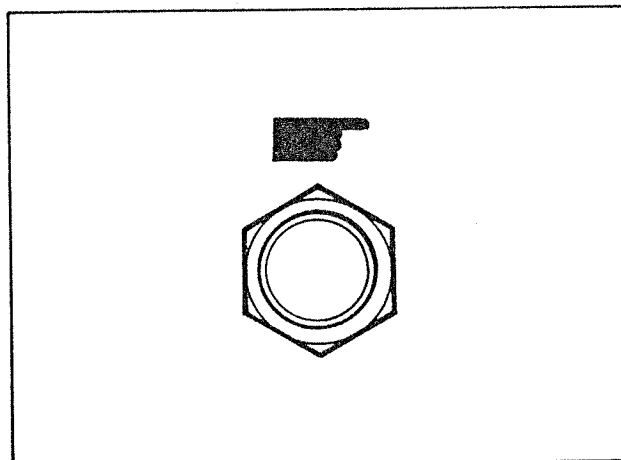
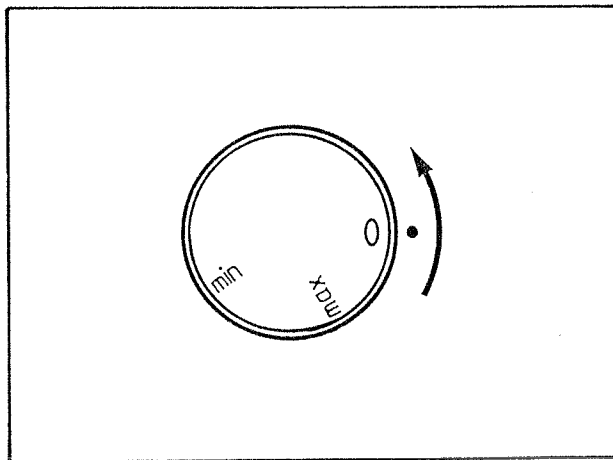
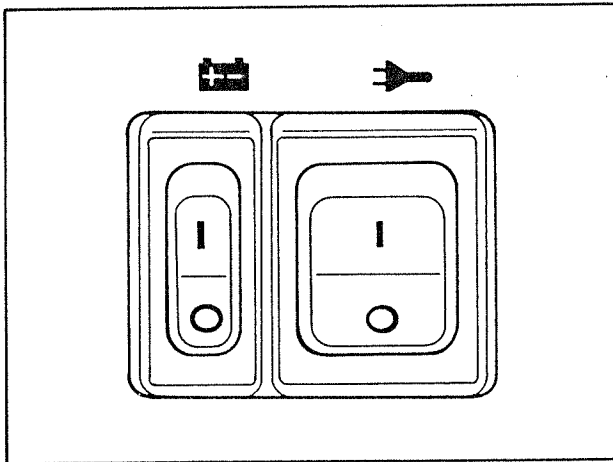

Liquid gas operation

- Set the switches for 220 V and 12 V to "0".
- Open the main cut-off valve (bottle valve) and the appliance cut-off valve (fridge).
- Turn the regulator to the "max." position, push it in and hold in position until the gas begins to flow to the burner.
- Press the ignition button firmly twice in quick succession.
- Keep pressing the regulator for fifteen seconds until the ignition cutout stays open by itself.
- The blue gas flame should be visible with the door open on the left hand side of the interior.
- If the flame is not burning, the above process should be repeated.

After the fridge has been operating for 24 hours with the regulator set to "max.", the setting can be reduced slightly to give a sufficiently cold temperature with somewhat less usage of gas.

TIP

When the flame goes out, the ignition cutout prevents the further supply of gas automatically.

Further information is available from the leaflet "Fridge Instructions".

When the external temperature rises above 25 °C or when vehicles with the surface at the rear are in direct sunlight, we suggest that you switch the temperature controlled fridge ventilator on. In models with the surface at the rear, there is an opening at the back of the rear, for getting better to the backside of the fridge.

ATTENTION

Never let unlighted gas leak out because of the danger of explosions.

7 Gas Appliances

To switch off the heating:

- Turn the regulator to "0" (automatic ignition will also be switched off).
- Close the cut-off valves on both the appliance and the main gas bottle.

TIP

The automatic ignition will keep on sparking until the gas is burning. If there is no gas supply, it will keep on sparking until the battery which feeds it is drained.

Because of this, always turn the regulator to "0" when the system is not in use to prevent the draining of the battery.

If the control light does not blink during ignition, or if it blinks more slowly than once every second, the battery probably needs replacing.

The user instructions supplied with the built-in heating system should always be followed.

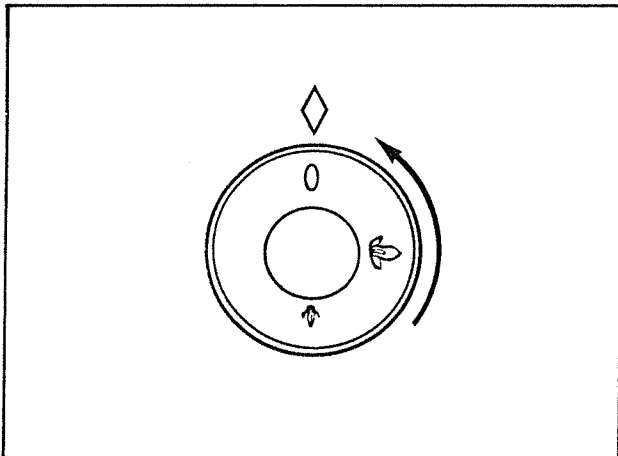

Cooker

To bring the cooker into service:

- Open the main cut-off valve (bottle valve) and the appliance cut-off valve (cooker).
- Turn the regulator to the desired position, either "large flame" or "small flame", push it in and hold in position until the gas begins to flow.
- Ignite the burner with a match or other ignition tool.
- Keep pressing the regulator for fifteen seconds until the ignition cutout stays open by itself.
- Set the regulator to the required setting.

To switch off:

- Turn the regulator clockwise to 0 setting. The flame goes out.
- Close the appliance and the main (gas bottle) cut-off valves.

TIP

When the flame goes out, the ignition cutout prevents the further supply of gas automatically.

Further information is available from the leaflet "User Instructions for Built-in Liquid Gas Cookers".

ATTENTION

The whole ignition process must be visible from above and should not be obscured by pots and pans.

The cooker must never be used as a form of heating.

Never let unlighted gas leak out because of the danger of explosions.

7 Gas Appliances

Boiler

The boiler runs off gas. The boiler's electrical control system runs off the 12 V circuit.

ATTENTION Never switch the boiler on when empty.

If the boiler is not in use, empty it if there is any danger of frost (see also section 10 "Winter care").

To guard the appliance against scaling, only use on the maximum temperature setting when lots of warm water is required.

Never let unlighted gas leak out because of the danger of explosions.

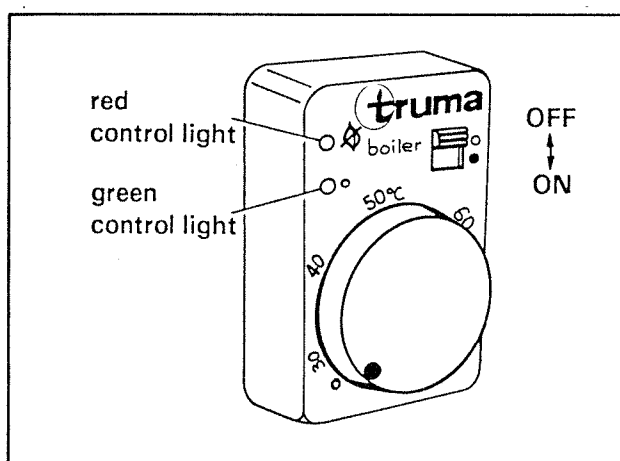

To switch on the boiler:

- Open the main cut-off valve (bottle valve) and the appliance cut-off valve (boiler).
- Set the required water temperature on the regulator.
- Switch on the 12 V electrical system.
- Set the switch to "●" (ON). The green control light should light up.

To switch off the boiler:

- Turn the regulator as far as it will go to the left.
- Set the switch to "0" (OFF).
- Close both the appliance and main (gas bottle) cut-off valves.

TIP If there is a fault, the red control lamp will light up (see section 12 "Error guide").

The user instructions supplied with the built-in boiler should always be followed.

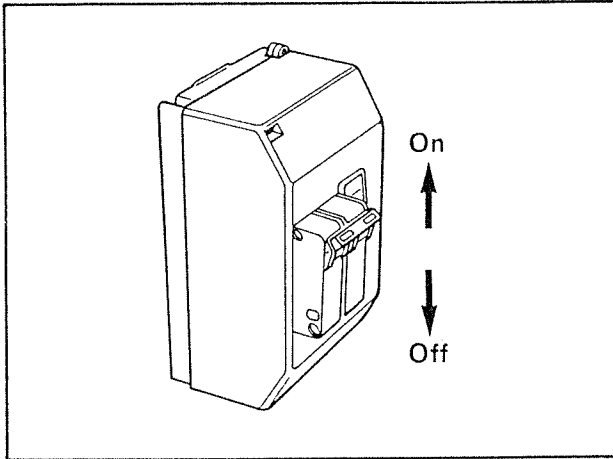

Supply

The 220 V connection (see external connection) is protected by a bi-polar fuse box.

When connected to the mains system

- the power points,
- the fridge and
- the 12 V system in the living quarters can all be used.

The additional battery (battery 2) is automatically re-charged from the battery charger. The current is automatically regulated to be consistent with the state of charge on the battery thus obviating an overload on the second battery.

When not connected to the mains, the 12 V system in the living quarters is provided

- via the starter battery when the engine is running
- via the second battery when the engine is idle.

When the engine is running, both batteries are being charged up by the alternator in the vehicle; when the engine is stopped, they are automatically disconnected from each other by a relay switch. This ensures that overuse of the electrical system in the living quarters cannot drain the starter battery. The vehicle is therefore always ready for starting.

To ensure that the second battery doesn't get run down too quickly, the fridge can only run on 12 V electricity when the engine is running.

In the "Hymermobil" models, the 12 V supply can be disconnected by means of an isolation switch (next to the 12 V fuse box). The key for the isolation switch can be retracted when the power is switched off.

TIP When the motorcaravan is out of use for a considerable time, the starter and second batteries should be charged up from time to time.

You will find the circuit diagrams for the base vehicle in the base vehicle manufacturer's manual.

The appliances should not be run from the second battery over a long period of time as this battery only has a limited capacity.

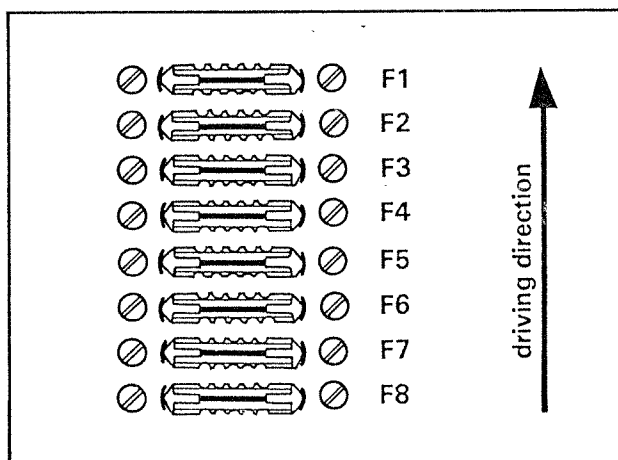

12 Volt Fuse Box (Body)

The appliances in the living quarters which run off 12 Volt supply are fused through a separate fuse box. This is to be found on the left hand side of the vehicle under the dashboard. To change a fuse, flip up the fusebox cover and read the function, value and colour of the appropriate fuse from the table below.

Fuse No.	Function	Value/Colour
F1	Water pump, shower light	8 Amp/white
F2	Switchbox, cooker hood, kitchen surface light, seating group light, wall mirror light, fridge ventilator, fridge ignition	8 Amp/white
F3	Fan, gas boiler, cab bed light, seating group light, driver's cab lights	8 Amp/white
F4	Battery charger	16 Amp/red
F5	Fridge	16 Amp/red
F6	Ammeter (appliances)	8 Amp/white
F7	Ammeter/Voltmeter (+ Batt 2, second battery)	8 Amp/white
F8	Voltmeter (+ Batt 1, starter battery)	8 Amp/white

ATTENTION To change a fuse, only use the values from the table above

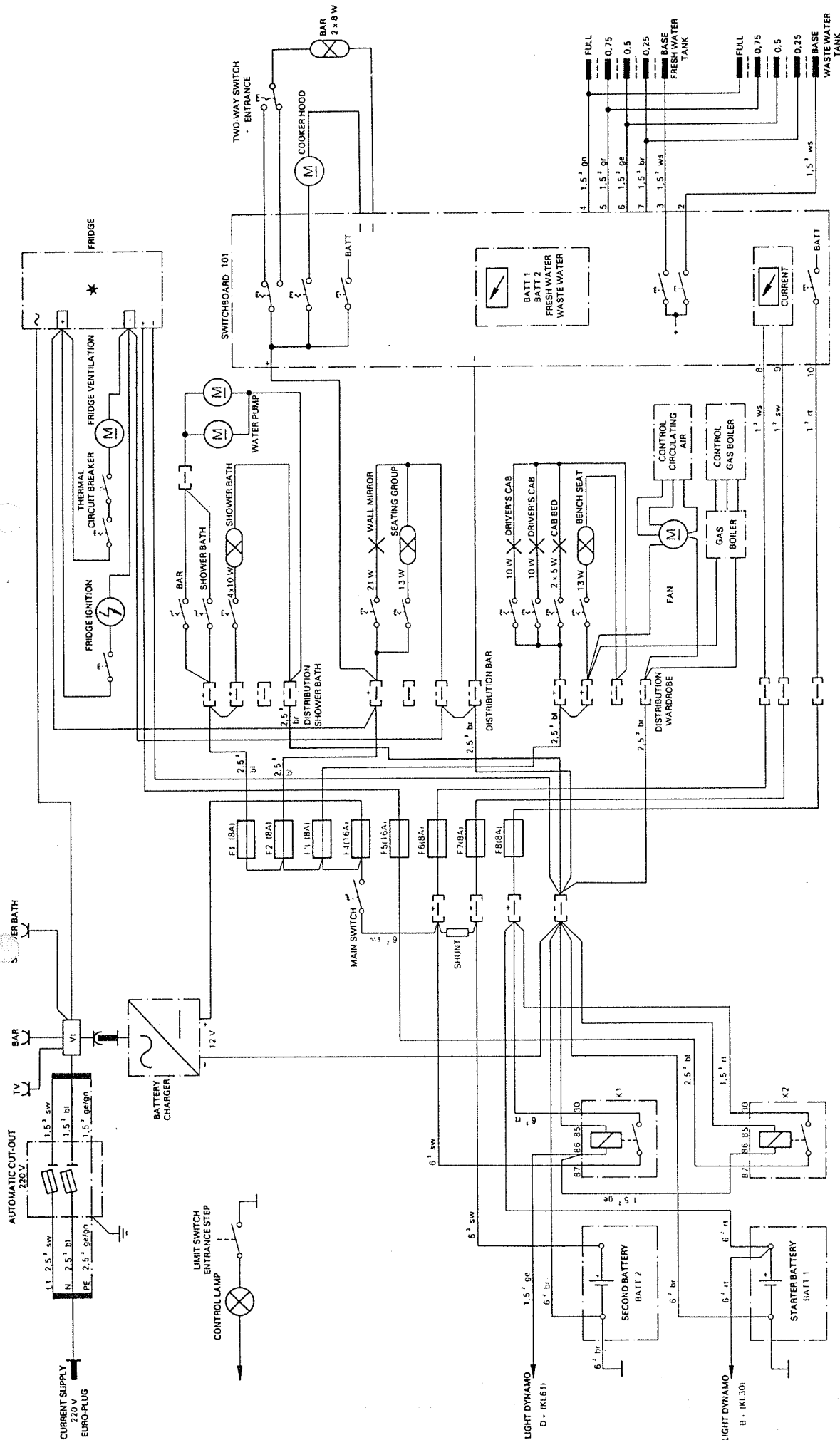

HYMERMOBIL 544, 555 CIRCUIT DIAGRAM

- CABLE COLOURS**
- bl blue
 - br brown
 - ge yellow
 - gn green
 - gr grey
 - rt red
 - sw black
 - ws white
- K1 ISOLATION RELAY: SECOND BATTERY-STARTER BATTERY**
- K2 ISOLATION RELAY: STARTER BATTERY-FRIDGE**
- (—) SCHUKO SOCKET (220 V)
 - (—) SCHUKO PLUG (220 V)
 - (—) FLAT PLUG CONNECTOR (12 V)
 - (—) DISTRIBUTOR (220 V)

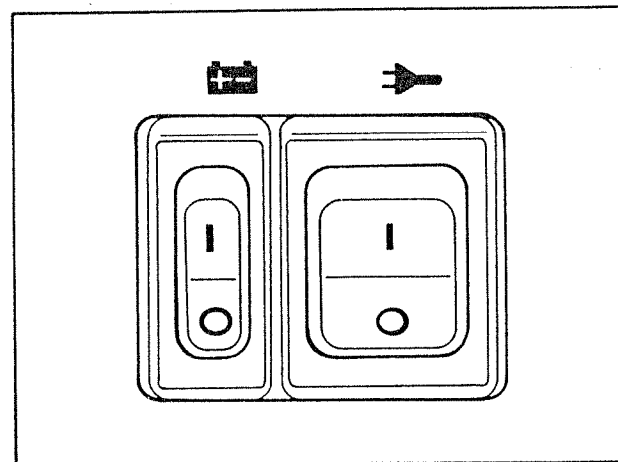
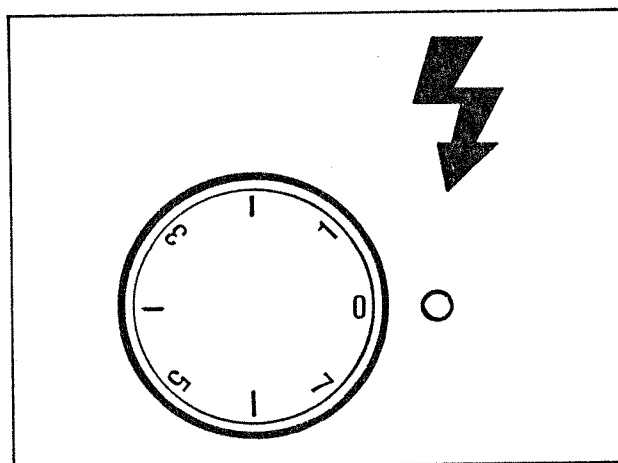
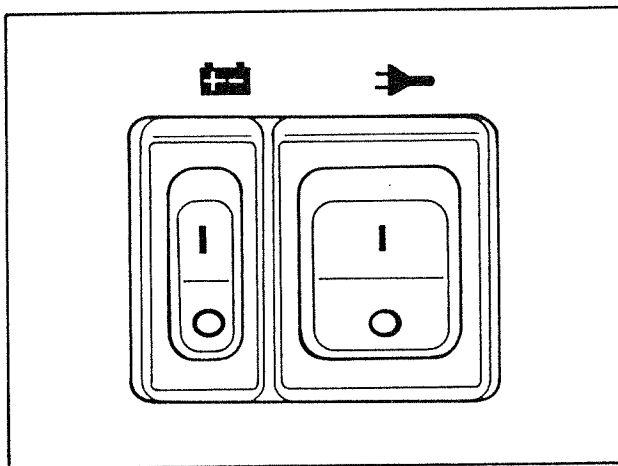

Fridge

The fridge has two modes of operation:

- Liquid gas operation (see Gas Appliances),
- Electrical operation (220 AC or 12 V DC).

For 220 V operation

- "12 V" switch on "0" and "220 V" switch on "I".

- Regulator knob (thermostat) should be switched to the desired position between "1" and "7".

- With the setting on "0" the appliance is without current on the 220 V side.

For 12 V operation

- "220 V" switch on "0" and "12 V" switch on "I".

TIP

In 12 V operating mode, the thermostat is non-effective.

Current can only be drawn from the starter battery when the motor is running since the connection is broken when the engine is switched off.

12 V operation does not provide for fully efficient cooling; rather it holds the temperature at the level previously achieved.

8 Electrical Appliance

TIP

When the external temperature rises above 25 °C or when vehicles with the work surface at the rear are in direct sunlight, we suggest that you switch the temperature controlled fridge ventilator on.

In models with the surface at the rear, there is an opening at the back of the rear, for getting better to the backside of the fridge.

Further information is available from the leaflet "Fridge Instructions".

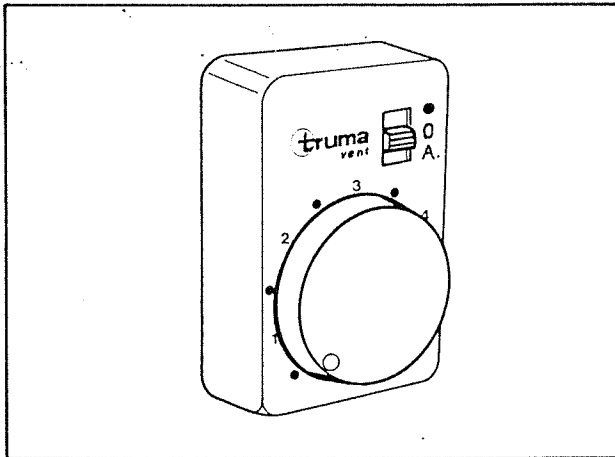

Air Circulation

The Trumavent fan combines with the gas heating system to provide for a better heat distribution in the motorcaravan. Set the required power setting on the control knob. The "0" setting switches the fan off.

TIP

Please consult the separate instruction leaflet.

Water Supply

The motorcaravan's water is supplied via a fresh water tank (canister). In the tank (canister) is an electrically driven immersible pump. It is switched on by means of an electrical regulator knob (water cock at the washbasins or in the washroom) respectively in models with a hydraulic pump by opening of the water cock (drag reduction). The waste water is collected in a foul water tank. By opening the drain tap the foul water tank can be emptied. There is an extension hose for the foul water connector in the rear bumper.

TIP Never use the pump when dry.

When the tank is refilled an air pocket can develop under certain conditions at the bottom of the pump. This stops the water from being taken up. Shake the pump well backwards and forwards in the water.

In areas with very unclean water (sand, lime etc.) the deposits of sand, lime etc. left behind in the water canister should be washed out from time to time.

In extreme conditions, a simple piece from a pair of nylon tights placed over the pump can guard against its sucking in small particles of dirt.

Water standing in, for example, tanks, canisters or hoses will become undrinkable after a relatively short time.

ATTENTION When there is the likelihood of frost, empty the whole water system (see section 10).

Washbasins

Open the covers for the washbasins, and set in the required position. Swing the water taps upwards.

TIP Always swing the taps downwards again before replacing the covers.

Washroom

- o Porta Potti

The Porta Potti can be set up next to the washbasin.

- o Thetford Cassette Porta-Potti

The WC is flushed using the vehicle's fresh water system, water being delivered via a magnet valve. To flush after use, press the flush button while at the same time turning it anti-clockwise. After flushing, turn the button clockwise again in order to re-close the extractor.

TIP Please take note of separate instructions.

ATTENTION When there is the likelihood of frost, empty the whole toilet system.

TIP Empty the Thetford-Cassette by observing the surroundings; this means at caravan sites equipped with an appropriated sewerage.

For cleaning we recommend the use of AQUA KEM GREEN. This product is with non-toxic and decomposable for 100 %.

Maintenance Of The Exterior

Wash your motorcaravan as often as possible with plenty of water. Spots of tar and dead insects should be removed as soon as possible. Avoid using anything which could scratch or mark the paintwork, such as brushes, coarse cloth, sponge or unsuitable cleaning materials. It is advisable from time to time to apply a good quality paintwork cleaner (car polish) to the external paintwork.

TIP We recommend you to undertake the "Major service" described in the service record booklet at least once a year.

We would also recommend you to have the inspection plan mentioned in the "Warranty booklet covering the 6 year vehicle seal guarantee" undertaken at the required intervals.

ATTENTION Acrylic window panes need particularly careful handling because of their sensitivity to scratching. Never rub them with a dry cloth! Never use chemical cleansing agents or window spray. The result would be that the panes would become brittle leading to cracks and splintering.

Wash the acrylic windows only with a clean sponge and a soft cloth using lots of water. If there is locked in grime, use only "Unipol", Part number 994519.

Smear the external hinges regularly with an acid-free grease in order to maintain the free movement of doors and flaps.

Internal Maintenance

Here you can use the normal cleaners which you would use around the house. Don't use any caustic cleaning materials.

Never clean the wash basins with scouring agents. Avoid anything which could scratch or scuff the surfaces. The stainless steel kitchen surfaces can always be restored to their original brightness using "Viennese lime".

Clean the furniture with a damp woollen cloth. When required, you can use a furniture polish on the varnished surfaces.

Never wash the upholstery; instead, clean it carefully using foam from a normal washing up liquid or with dry foam. The curtains are best taken to the dry cleaners.

Winter Maintenance

The widespread use of salting in winter is detrimental to the undersides of vehicles and to parts open to spray from the road. It is sensible therefore to wash the vehicle thoroughly and regularly in winter in order to wash off some of the salt. In particular, the underside, mechanical and exposed parts require very thorough cleaning.

As a preventative measure you can use wax based preservatives on the underside of the vehicle, or else a recommended underseal (Part No. 217026). Mechanical parts which have to rub against each other should

10 Maintenance

(in winter) be lubricated more often (locks, hinges etc.).

ATTENTION Please make sure when camping in winter that the heating is left on at around 15 °C during frosty nights and, when fitted, that the circulation fan is left at least on its automatic setting. Internal doors and flaps should be left slightly ajar as well whenever the external temperature is extreme. This will allow warm air to get into storage areas preventing pipes (e.g. in the water system) from freezing up. It will also stop the build up of condensation in these areas.

Make sure the chimney is kept free from snow and use a chimney extension.

If you are not using the motorcaravan during winter, drain the whole water system to prevent damage in the vehicle (especially from the boiler). Open the two valves; the drain valve by turning the valve cap anti-clockwise (position of the drain valve see page 37), the pressure valve by placing the valve lever in a vertical position. When you follow this procedure, you will have a guarantee for an acceptable draining off and bleeding of the fresh water system and therefore no damage by frost:

1. Switch off the 12-V-electrical system (switch on the switchboard respectively master switch).
2. Remove the cover from the cleansing hole of the water tank.
3. Pull the stopper of the outflow out of the tank.
4. Place the mixing battery in the kitchen and in the shower bath (toilet area) exactly in central position (warm - cold).
5. Hang on the handspray in shower position.
6. Open both drain valves for cold- and warm water.

Generally you have to isolate the lower part of the fridge, whenever the external temperature is extreme, the upper part of the fridge too.

During frosty days and nights we recommend the use of an insulation mat to cover the front of the motorcaravan.

Laying Up The Vehicle

If you want to lay your motorcaravan up for a long period of time, we would recommend that you fill the fuel tank to the very top. You can thus prevent the possible corrosion which would otherwise ensue as a result of condensation within the tank.

ATTENTION Before beginning a journey after the vehicle has been laid up, it is advisable to let an authorised workshop test the whole braking system.

Empty the whole water system, when you want to lay up your motorcaravan for a short period of time. Remove the water, resting in hoses, by pressing. After a short time, water will be not drinkable.

Before reoperating, you should flush the hoses by fresh water. Open therefore all cocks.

Type	Position of the drain valve
Hymercar 46	Kitchen surface
Hymercamp 51	Wardrobe, below, floorboard with flap
Hymercamp 52	Kitchen area, to the right of the fridge
Hymercamp 55	Kitchen area, to the right of the fridge
Hymercamp 57	Wardrobe, below floorboard with flap
Hymercamp 56	Right hand bench seat, beside kitchen area
Hymercamp 64	Right hand bench seat, beside wardrobe
Hymercamp 65	First under-bed storage, right at the rear
Hymertramp 155	Kitchen area, to the right of the fridge
Hymertramp 164	Right hand bench seat, beside wardrobe
Hymertramp 165	
Hymermobil 534	Rear left hand bench seat
Hymermobil 544	Kitchen area, to the right of the fridge
Hymermobil 550	Rear left hand bench seat
Hymermobil 554	Right hand bench seat, beside kitchen area
Hymermobil 555	Kitchen area, to the right of the fridge
Hymermobil 560	Wardrobe, below, floorboard with flap
Hymermobil 564	Wardrobe, below, floorboard with flap
Hymermobil 644	Rear left hand bench seat, next to toilet area
Hymermobil 654	First under-bed storage, right at the rear
Hymermobil 660	Rear right hand bench seat, next to toilet area
Hymermobil 665	Rear right hand bench seat, next to toilet area
Hymermobil 670	First under-bed storage, right at the rear
Hymermobil 694	Rear right hand bench seat, next to toilet area
Hymermobil 700	Rear right hand bench seat, next to toilet area

10 Maintenance

Major Valeting

The "major valeting" operation comprises (taken from the EHW service booklet)

- Washing with car shampoo,
- Cleaning the underbody and touching up the underseal,
- Treating corrosible parts with underseal,
- Polishing the acrylic windows,
- Polishing with car wax,
- Greasing mechanical parts and
- Touching up paintwork.

TIP

We recommend that the "major valeting" operation described in the service booklet is undertaken at least once every year.

Servicing

Like every other technical product, a vehicle requires servicing. The scope and the frequency of the servicing depends in the first instance on the (often greatly different) modes and conditions of use. When operated under severe conditions, the vehicle must be serviced more frequently than would otherwise be the case.

The work of inspection and servicing requires much professional knowledge which cannot be distilled into the pages of this booklet. You are advised to let only properly trained and qualified people do this work. Such people are available at all Eriba-Hymer service stations. Experience, and regular technical instruction as well as the right facilities and tools for the job, guarantee up-to-date and professional care for your vehicle. The Eriba-Hymer service station certifies in the service booklet the service work which they have undertaken on each occasion.

In order for your vehicle to maintain its value, it is also important that servicing is carried out at the required interval by EHW trained and recommended service personnel.

ATTENTION Please take note of the service work set out in the service booklet and make sure, in the interests of your own safety, that it is carried out at the regular intervals by authorised personnel.

TIP The service record acts as evidence in the event of later damage or warranty claims.

Official Inspections

Please note that motorcaravans registered in the Federal Republic have to undergo, once every two years an official inspection ("TÜV", "DEKRA") according to para 29 StVZO. In other countries the appropriate regulations will apply.

The gas system has to be checked once every two years by a qualified gas specialist. The successful completion obligatory tests will be set out by the qualified tester on a gas test certificate. The gas test plate must be displayed on the rear of the vehicle near to the number plate.

11 Aftercare And Servicing

Spare Parts

Our agents and service centres are always ready to provide you with spare parts when required. Parts cannot, however, be dispatched directly from the factory.

When you order your spare parts, please give the serial number and the type of your vehicle as well as the appropriate Hymer part number

Here are the most important spare parts:

600 mm Windscreen wipers	Hymer, part No. 41417
Wiper arms	Hymer, part No. 41416
Wiper motor (DB vehicle)	Hymer, part No. 41400
Wiper motor (Fiat vehicle)	Hymer, part No. 41400.1
Windscreen	Hymer, part No. 39603
Sliding window - left side	Hymer, part No. 39677
Sliding window - right side	Hymer, part No. 39678
Sliding window - driver's cab	Hymer, part No. 39652
Rigid window in front of driver's cab door	Hymer, part No. 39680
Vehicle paint	RAL 9001, Playa metallic

The vehicles represented in this user manual are conceived and equipped according to strict construction norms. Useful accessories are offered in the accessory catalogue.

Your Eriba-Hymer dealer will gladly advise you.

When adding accessories, please make sure that these do not have to be registered as such for TÜV

TIP Eriba-Hymer can take no responsibility for possible danger, whether to persons or their property, from accessories not offered for sale by the factory (works prospectus or accessories catalogue) and not fitted at the factory itself or by an authorised dealer (or agent).

Changing A Wheel

When changing a wheel, consult the base vehicle manufacturer's guidelines.

- ATTENTION** Where possible, the motorcaravan should be on level ground.
- The handbrake should be fully engaged before the vehicle is lifted.
- Secure the vehicle against rolling by using a wedge under the wheels.
- Never fasten the jack onto the bodywork.
- Never jack up the motorcaravan while the vehicle supports are in place.

Faults Guide

ATTENTION In the interests of your own safety, always let repairs and installations which involve the braking system be undertaken by authorised service personnel.

Electrical Appliances		
Fault	Cause	Remedy
Lighting system no longer functions effectively	Bulb defective	Unscrew the housing of the affected light. Replace bulb. Check Voltage and Wattage are correct
	Blown fuse	Change fuse
No 220 V mains electricity despite connection.	Safety cutout switched out	Switch safety cutout back on

Gas Appliances		
Fault	Cause	Remedy
Smell of gas, high usage of gas	Leak in system	<p>ATTENTION</p> <p>Switch off appliance immediately close bottle valve open windows and doors for ventilation. Get a professional to test the system. Don't use electrical switches (e.g. starter). No open flames or smoking</p>

12 In An Emergency

Cooker		
Fault	Cause	Remedy
Ignition cutout fails to engage (flame does not continue to burn when regulator control is released)	Cooker blind is too near the front	Push the blind to the rear by hand until it can be operated freely
	Ignition cutout defective	Consult a professional
Flame goes out when set on low	Ignition cutout probe out of place	Reset the probe correctly (do not bend). The probe tip should overtop the burner by about 5 mm. The probe neck should not be further than 3 mm from the burner ring; if necessary consult a professional

Fridge and heating

If a fridge or heater proves defective, get in touch with the nearest service centre belonging to the appropriate manufacturer. The address list is amongst the literature you received with the appliance. Otherwise, send a short report detailing the fault, the number of the appliance and your correct address direct to TRUMA or Electrolux-Service.

Boiler		
Fault	Cause	Remedy
Red control lamp "Fault" lights up	Air in gas system	Switch off and on again. After two unsuccessful attempts, leave for 10 minutes before trying again
	No gas	Check whether main and bottle valves are open Attach full bottles
	Defective cutout part	Consult professional
Neither of the two control lamps lights	Fuse blown	Insert new fuse
	Battery in living area flat or defective	Charge battery (or have it charged)/get new battery

Water supply		
Fault	Cause	Remedy
Water leaking into vehicle	Loose seal	Find the loose seal, refit and re-seal the water supply hose
No water	Fresh water tank empty	Fill with water
	Fuse blown	Reset 220 V fuse or replace 12 V fuse
	Defective pump	Replace pump
	Battery charger defective	Consult professional
	Hose twisted	Straighten or replace hose

Bodywork		
Fault	Cause	Remedy
Rooflight difficult to open	Gas pressure springs defective	Fit new gas pressure springs
Winding roof light difficult to open	Winder thread not greased	Grease winder thread
	Defective winder	Replace winder

TIP Our service-outlets and agents are always ready to meet your need for spare parts.

Dealers list - West Germany

- | | | | |
|------|---|------|---|
| 1000 | Wohnwagen Dr. Schötzau + Sohn
Inh. Jörg Schötzau
Breisgauer Str. 1a
1000 Berlin 38
Tel. 0 30/80 33 00 93 | 3004 | Eriba-Hymer-Verkaufsnieder-
lassung
Hannoversche Straße 31
3004 Isernhagen 1
(Altwarmbüchen)
Tel. 05 11/61 21 91 |
| 2000 | Wohnwagen-Bergmann
Holsteiner Chaussee 402 (B 4)
2000 Hamburg-Schnelsen
Tel. 0 40/5 50 20 67
Telex 2 16 45 13
Telefax 0 40/5 59 12 73 | 3223 | Wohnwagen Brendes OHG
Dörshelf 1
3223 Delligsen 1
Tel. 0 51 87/15 55 |
| 2313 | Krüger Caravan KG
Gewerbegebiet B 76
2313 Raisdorf bei Kiel
Tel. 0 43 07/70 52 | 3300 | Caravan-Center
Günter Gerking
Hauptstr. 17
3300 Braunschweig
Tel. 0 53 07/30 04 |
| 2350 | Caravan Hofmann
Wasbeker Straße 349
2350 Neumünster
Tel. 0 43 21/6 55 76
Telefax 0 43 21/6 49 34 | 3392 | Wohnwagen Brendes OHG
Andreas-Berger-Str. 21
3392 Clausthal-Zellerfeld
Tel. 0 53 23/36 08 |
| 2805 | Caravan und Freizeit
Claus Jürgen Vörtmann
Bremer Straße 40-44
2805 Brinkum (Stuhr 1) bei Bremen
Tel. 04 21/89 09 39
und 89 13 56 | 3578 | Reisemobil- und Caravan-Center
Dickhaut (Autohaus Kohl)
Wierastraße 3-7
3578 Schwalmstadt-Treysa
Tel. 0 66 91/2 02 17
Telefax 0 66 91/2 02 17 |
| 2900 | Wohnwagen + Reisemobile
H. J. Faßbender
Wilhelmshavener Heerstraße 49
2900 Oldenburg
Tel. 04 41/3 07 70 | 4050 | Caravan- und Reisemobil-
vertrieb Ortman GmbH
Krefelder Straße 81
4050 Mönchengladbach
Tel. 0 21 61/20 76 00 |
| 2942 | Friesischer Caravan-Vertrieb
Inh. H. G. Söker
Postfach 211
Mühlenstraße 68, an der B 210
2942 Jever (Oldb.)
Tel. 0 44 61/20 95-96
Telefax 0 44 61/44 14 | 4130 | Ortman GmbH
Caravan- und Reisemobilvertrieb
Werkstatt, Ersatzteile, Zubehör
Essenberger Straße 27
Fahrzeug-Ausstellung u. Verkauf
Klever Str. 58 (B57)
4130 Moers 1
Tel. 0 28 41/5 40 37 |

13 Index Of Service Stations

- 4330 T.E. Caravans GmbH
Kölner Straße 35-37
4330 Mühlheim/Ruhr
Tel. 02 08/48 50 51
Telex 85 69 15
Telefax 02 08/48 16 79
- 4350 MOHAG Freizeit-Center
Hertener Straße 88-100
Postfach 10 25
4350 Recklinghausen-Stadt
Tel. 0 23 61/58 04 20
Telefax 0 23 61/11 79 96
- 4400 Caravan-Reisemobil-Centrum
C. H. Brackmann
Gildenstraße 16
4400 Münster-Handorf
Tel. 02 51/32 82 60
Telefax 02 51/32 71 23
- 4500 Heinrich Unnewehr GmbH & Co KG
Anhängerszentrale
Lengericher Landstraße 11
4500 Osnabrück-Hellern
Tel. 05 41/44 11 41-42
Telefax 05 41/44 33 59
- 4600 Wohnwagen Dürrwang GmbH & Co
Nortkirchenstraße 63
(B 54, Abfahrt Romberg-Park)
4600 Dortmund 30 (Hörde)
Tel. 02 31/43 60 68
Telefax 02 31/43 56 32
- 4790 Caravan-Vertrieb Paderborn
J. Palmowski
Detmolder Straße 55
4790 Paderborn
Tel. 0 52 51/5 66 98
- 4800 Caravan- und Reisemobil-
Vertrieb J. Palmowski
Herforder Straße 475
4800 Bielefeld
Tel. 05 21/7 29 81
- 5000 Reisemobile Gerhard Beck
Unterbuschweg 87
Gewerbegebiet Rodenkirchen
5000 Köln 50
Tel. 0 22 36/6 13 34
- 5030 Camping-Center H. Twiestmeyer
Luxemburger Straße 114-116
Autobahnausfahrt
Köln-Klettenberg
5030 Hürth 5 (Efferen)
Tel. 0 22 33/6 49 35
Telefax 0 22 33/6 47 33
- 5138 EWO-Caravan- und Reisemobil-Center
Von-Liebig-Straße
(gegenüber Allkauf)
5138 Heinsberg
Tel. 0 24 52/44 66
Telex 83 28 67 ewo
- 5238 Camping Wessler
Koblenzer Straße 32/B 413
5238 Hachenburg
Tel. 0 26 62/22 87
Telefax 0 26 62/34 38
- 5275 Karosseriebau Faulenbach GmbH
Kölner Straße 304
5275 Bergneustadt
Tel. 0 22 61/4 19 24
Telefax 0 22 03/4 42 77
- 5472 Camping-Center Klein GmbH
An der A61
Postfach 12 07
5472 Plaidt
Tel. 0 26 32/7 29 25
Telefax 0 26 32/7 29 25
- 5650 Zierold GmbH
ERIBA-Caravan- und Reisemobile
Merscheider Straße 215-221
5650 Solingen 11 (Ohligs)
Tel. 02 12/33 40 95
- 5900 Caravanpark Siegerland GmbH
Porschestraße 42
5900 Siegen 1
Tel. 02 71/40 32 11
Teletex 27 13 43 AUWAL
Telefax 02 71/4 69 14

- 6000 Reisemobile Rutenkolk
Herbert Rutenkolk
Friedberger Landstraße 434
6000 Frankfurt 60
Tel. 0 69/47 45 45
Telefax 0 69/47 42 07
- 6254 WEWO M.T. Welzenberg
Reisemobil-Camping-Caravan
Vor der Eichen 16
6254 Elz-Limburg
Tel. 0 64 31/5 12 99
Telefax 0 64 31/5 45 99
- 6300 Kunze Caravan und Sport
Gottlieb-Daimler-Straße 15
6300 Gießen
Tel. 06 41/6 10 34 und 35
Telefax 06 41/6 75 45
- 6434 Reisemobil- und Caravan-Center
Dickhaut (Autohaus Kohl)
Hattenbacher Straße 38
6434 Niederaula
Tel. 0 66 25/76 44
- 6500 Moser Wohnwagen und Reise-
mobile GmbH
Curiestraße 24
6500 Mainz-Hechtsheim
Tel. 0 61 31/5 90 03 und 5 90 04
Telex 4 18 77 26
Telefax 0 61 31/59 20 72
- 6600 Wohnwagen Vogt GmbH
Koblenzer Straße 53
6600 Saarbrücken 5
Tel. 06 81/79 12 00
Telex 4 42 11 08
Telefax 06 81/79 12 00
- 6900 Hans Schneider KG
Speyerer Straße 20
6900 Heidelberg 1
Tel. 0 62 21/1 33 33 und 3 33 33
- 7032 Wohnwagen Rall GmbH
Mahdentalstraße 72
7032 Sindelfingen
Tel. 0 70 31/83 04-1
- 7100 R. Sperrfechter GmbH
Lämlinstraße 13
7100 Heilbronn-Böckingen
Tel. 0 71 31/4 40 58-59
Telex 72 89 24
Telefax 0 71 31/4 41 59
- 7500 Autohaus Bauer GmbH
Killisfeldstr. 36
7500 Karlsruhe 41 (Durlach)
Tel. 07 21/69 51 88
- 7590 Caravan- und Reisemobil-
vertrieb Hermann Schnurr
Neulandstraße 6 (Gewerbegebiet)
7590 Achern
Tel. 0 78 41/50 14
Telefax 0 78 41/50 70
- 7750 Wohnwagen und Reisemobile
Walter Wiest
7750 Konstanz 19 - Dettingen
Tel. 0 75 33/47 06
Telefax 0 75 33/42 45
- 7800 Wohnwagen und Reisemobile
Walter Wiest
Niederlassung
Industriegebiet auf der Haid
Friedrich-Neff-Straße
7800 Freiburg
Tel. 07 61/48 47 25 und 48 47 17
Telefax 07 61/49 98 98
- 7967 ERIBA-HYMER GmbH
Verkaufsniederlassung
Biberacher Straße 98
7967 Bad Waldsee
Tel. 0 75 24/70 01 06
und 70 01 08
Telex 73 27 92
Telefax 0 75 24/70 01 07
- 8000 ERIBA-HYMER GmbH
Verkaufsniederlassung München
Bodenseestraße 200
8000 München 60
Tel. 0 89/8 34 38 93
und 87 74 09
Telefax 0 89/8 71 27 55

13 Index Of Service Stations

- 8200 Schrempf + Lahm OHG
Kolbermoorer Str. 24
8200 Rosenheim
Tel. 0 80 31/4 23 25
Telefax 0 80 31/4 67 65
- 8360 Autohaus Stieler
Hengersberger Str. 88
8360 Deggendorf
Tel. 09 91/50 58 und 50 59
Telefax 09 91/3 29 06
- 8400 Lanzinger Caravan GmbH
Donaustauer Str. 112
8400 Regensburg
Tel. 09 41/4 51 60
- 8500 Diepold GmbH Wohnmobile
Haerberleinstr. 4
8500 Nürnberg 10
Tel. 09 11/52 30 38
Telefax 09 11/5 21 66 32
- 8670 Autohaus Fränkel
Caravan und Reisemobile
An der Angerbrücke
8670 Hof-Saale
Tel 0 92 81/8 48 87 und 8 69 87
Telefax 0 92 81/22 29
- 8781 Volkert GmbH Wohnwagen
Campingplatz
8781 Weickersgrüben
über Gemünden am Main
Tel. 0 93 57/4 85
Telefax 0 93 57/12 08
- 8868 Wohnwagenvertrieb H. Meyer KG
Romantische Straße 14-17
8868 Möttingen
Tel. 0 90 83/6 10 und 6 19
Telefax 0 90 83/2 74
- 8870 HEWA Reisemobile und
Freizeit GmbH
Heidenheimer Str. 115
8870 Günzburg
Tel. 0 82 21/63 67
Telefax 0 82 21/3 26 57
- 8901 Bauer Caravan und
Freizeit GmbH
Augsburger Straße 36
8901 Affing-Mühlhausen
Tel. 0 82 07/10 77 und 10 78
Telefax 0 82 07/84 54
- 8965 Allgäuer-Wohnwagen-Zentrale
Peter Mair
8965 Wertach/Allgäu
Tel. 0 83 65/3 26
Funk-Tel. 0 16 12 82 11 60

Eriba-Hymer Euro-Service

Austria	Eriba-Hymer Generalimporteur Sterneckstraße A-5020 Salzburg Tel. 06 62/7 36 35	Luxembourg	Camping-Loisirs Paul Johanns 6 Kellereiswee L-5450 Stadtbredimus Tel. 6 96 75
Belgium	P. V. B. A. Campirama Ringlaan 9 B-8710 Heule-Kortrijk Tel. 0 56/35 62 58	Netherlands	Eriba-Nederland B. V. Ambachtsstraat 10 NL-3371 XA Hardinxveld- Giessendam Tel. 0 18 46/35 46
Denmark	Camping Grossisten Fabriksvej 9 DK-6000 Kolding Tel. 05/52 11 86	Norway	T. Wiken Nielsen A/S Postbox 274 N-3251 Larvik Tel. 0 34/1 57 40
Finland	Touring Cars Majaniementie 1 SF-70420 Kuopio Tel. 9 71/34 18 00 Kodika Oy SF-28400 Ulvila Tel. 9 39/38 77 20	Sweden	Husbilar I Stockholm AB Girgis Aziz Glömstavägen 31 S-14144 Huddinge Tel. 08/7 46 75 70
France	Hymermobil SARL Importateur Exclusif RN 66 - BP No. 46 F-68700 Cernay Tel. 89/75 64 87	Switzerland	Eriba-Hymer GmbH Holzstr. 19 D-7967 Bad Waldsee Tel. 0 75 24/7 00-0 Telefax 0 75 24/7 00-2 20
Greece	Mac Nic Camping Hellas Co. P. C. 16 675 GR-Glyfada Athens Tel. 01/9 62 72 45	Spain	Motorcaravan S. A C/Manlleu 30 N.I.F.A 58 406 927 8500 Vic (Barcelona) Tel. 93/8 86 06 33 Caravaning 4 Caminos Armando Tregon Ctra. N-II, de Madrid a Barcelona KM 607,2 Aportado de Correo 96 Molins de Rei (Barcelona) Tel. 93/6 56 12 81
G.B.	Madisons Hymermobile Centre Blackpool Road, Clifton Preston Lancs. PR4 0XN Tel. 07 72/68 46 19 Telefax 07 72/67 12 00 Telex 6 71 45	Turkey	HEWA Turizm ve Ticaret A.S. Kira Otokaravan P.K. 18 48670 Güllük/Milas Tel. 2 31 79 48
Italy	Michael Eckl Via Portofino 8 I-30038 Spinea/Venezia Tel. 041-4 35 58 50		

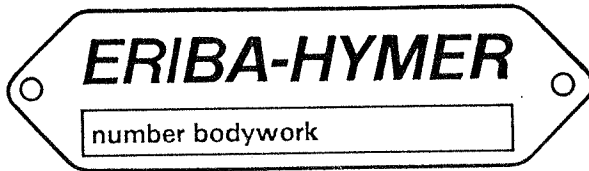

Position Of Number Plates

The serial number plate with the assembly (bodywork) number is situated in the region of the entrance to the vehicle (either to the left or the right of the door).

TIP The assembly (bodywork) number is the same as the serial number. When referring the vehicle to the service station please always quote the serial number.

Pressures Guide For Tyres

Type	Type pressure	front	rear
Hymercamp 46		3,50	3,80
Hymercamp 51 (2,55 t bzw. 2,6 t)		3,50	3,20
Hymercamp 51 (2,8 t bzw. 3,2 t)		4,30	4,50
Hymercamp 52 (2,55 t bzw. 2,6 t)		3,50	3,20
Hymercamp 52 (2,8 t bzw. 3,1 t)		4,30	4,50
Hymercamp 55		4,30	4,50
Hymercamp 56		4,30	4,50
Hymercamp 57		4,30	4,50
Hymercamp 64		4,30	4,50
Hymercamp 65		4,30	4,50
Hymertramp 155		4,30	4,50
Hymertramp 164		4,30	4,50
Hymertramp 165		4,30	4,50
Hymermobil 534		4,30	4,50
Hymermobil 544		4,30	4,50
Hymermobil 550		3,25	4,50
Hymermobil 554		4,30	4,50
Hymermobil 555		3,25	4,50
Hymermobil 560		3,25	4,50
Hymermobil 564		4,30	4,50
Hymermobil 564		4,30	4,50
Hymermobil 644		4,30	4,50
Hymermobil 654		4,30	4,50
Hymermobil 660 (3,5 t)		3,00	4,50
Hymermobil 660 (4,6 t)		3,25	4,50
Hymermobil 665		3,25	4,50
Hymermobil 670		3,25	4,50
Hymermobil 694		4,30	4,50
Hymermobil 700		3,25	4,50

Tyre pressures given in bar

TIP For further information see base vehicle manufacturer's instruction manual.

Table Of Technical Data

ATTENTION The indications in the vehicle registration document are binding for the technical data.

By the assemblage of accessories the dimensions and the own weight of the vehicle can be changed.

For further information see base vehicle manufacturer's instruction manual.

Hymermobil 534/544/554

Manufacture	Fiat	Fiat	Fiat	Fiat
Model	Petrol-Kat	Diesel Oil	TD	TD
Type	Ducato 14	Ducato 14	Ducato-TD 14	Ducato 14
Efficiency/kW (PS)	62 (85)	55 (75)	60 (82)	70 (95)
Volume/cm ³	2000	2500	1900	2500
Length/mm	5630	5630	5630	5630
Breadth/mm	2220	2220	2220	2220
Height/mm	2750	2750	2750	2750
Wheel base/mm	2923	2923	2923	2923
Greatness of tyre	(1)	(1)	(1)	(2)
Sort of fuel	*	Diesel Oil	Diesel Oil	Diesel Oil
Petrol tank	70 l	70 l	70 l	70 l
Fuel mileage	11...14	10...13	10...13	10...13
Maximum speed/km/h	120	115	120	125
Wheel gauge in front/mm	1690	1690	1690	1700
Wheel gauge behind/mm	1650	1650	1650	1650
Turning circle/m	12,2	12,2	12,2	12,2
Gear box	5	5	5	5
Number of cylinder	4	4	4	4
Compression	8 : 1	22 : 1	18 : 1	18 : 1
Perm. gross/kg	2800	2800	3100	3100
Perm. load fauled/kg	(3)	(3)	(4)	(4)
Perm. number of persons	4 till 6, dependant on equipment			
Fresh water supply	100 l	100 l	100 l	100 l
Foul water tank	100 l	100 l	100 l	100 l
Gas supply	2x11 kg	2x11 kg	2x11 kg	2x11 kg

(1) 185 R14 C 8 PR

(2) 195/75 R16 C

(3) braked; 2000 till 10 % ascending

(4) braked; 1700 till 10 % ascending

* Petrol non-leaded

14 Technical Data

Hymermobil 534/544/554

Manufacture	Peugeot	Peugeot	Peugeot	Citroen	Citroen	Citroen
Model	Petrol	Diesel Oil	TD	Petrol	Diesel Oil	TD
Type	J5/1300	J5/1300	J5/1300	C25/1400	C25/1400	C25/1400
Efficiency/kW (PS)	55 (75)	54 (74)	68 (92)	55 (75)	54 (74)	70 (95)
Volume/cm ³	1971	2500	2500	1975	2482	2482
Length/mm	5630	5630	5630	5630	5630	5630
Breadth/mm	2220	2220	2220	2220	2220	2220
Height/mm	2750	2750	2750	2750	2750	2750
Wheel base/mm	2923	2923	2923	2923	3653	3653
Greatness of tyre	(1)	(1)	(2)	(1)	(1)	(2)
Sort of fuel	Petrol	Diesel Oil	Diesel Oil	*	Diesel Oil	Diesel Oil
Petrol tank	70 l	70 l	70 l	70 l	70 l	70 l
Fuel mileage	14...16	10...13	12...14	14...16	10...13	10...13
Maximum speed/km/h	120	110	120	120	110	120
Wheel gauge in front/mm	1682	1682	1682	1682	1682	1682
Wheel gauge behind/mm	1650	1650	1650	1650	1650	1650
Turning circle/m	12,2	12,2	12,2	12,2	12,2	12,2
Gear box	5	5	5	5	5	5
Number of cylinder	4	4	4	4	4	4
Compression	8 : 1	22 : 1	18 : 1	8 : 1	22,25 : 1	
Perm. gross/kg	2800	2800	3100	2800	2800	2800
Perm. load fauled/kg	(3)	(3)	(4)	(3)	(3)	(3)
Perm. number of persons	4 till 6, dependant on equipment					
Fresh water supply	100 l	100 l	100 l	100 l	100 l	100 l
Foul water tank	100 l	100 l	100 l	100 l	100 l	100 l
Gas supply	2x11 kg	2x11 kg	2x11 kg	2x11 kg	2x11 kg	2x11 kg

(1) 185 R14 C 8 PR

(2) 195/75 R16 C

(3) braked; 2000 till 10 % ascending

(3) braked; 1700 till 10 % ascending

* Petrol non-leaded